16MY Outlander PHEV Emergency Procedure Manual

'15-11

No.PMRE1501



Introduction

This manual provides safety instructions that need to be followed when rescuing the passengers from the vehicle after an accident and describes how to handle the damaged vehicle.

Failure to follow these instructions and especially the warnings and cautions may result in serious injury such as an electrical shock due to the high voltage battery installed on Outlander PHEV.

Please read and understand this manual carefully for your and the passengers safety.

Throughout this manual the words **WARNING**, **CAUTION** and **NOTE** appear. These serve as reminders to be especially careful. Failure to follow instructions could result in personal injury or damage to your vehicle.

 **WARNING;**

Indicates a strong possibility of severe personal injury or death if instructions are not followed.

 **CAUTION;**

Means hazards or unsafe practices that could cause minor personal injury or damage to your vehicle.

NOTE:

Gives helpful information.

*: indicates optional equipment.

It may differ according to the sales classification; refer to the sales catalogue

Mitsubishi Motors reserves the right to make changes in design and specification and/or to make additions to or improvements in this product without obligation to install them on products previously manufactured.

- Please note that the contents of this manual may not fit completely with actual vehicle due to the change of vehicle specification.

-
1. Safety precaution for handling high voltage
 - (1) Isolation from the high voltage circuit
 - (2) Disconnection of the high voltage circuit
 - (3) Precautions when rescuing passengers

 2. High voltage components location
 - (1) High-voltage component and wiring harness locations
 - (2) SRS airbag system

 3. Features on vehicle exterior
 - (1) Feature list
 - (2) Features on exterior
 - (3) Feature in the engine compartment and centre pillar

 4. What is necessary at the accident site
 - (1) Required tools, etc. at the accident site
 - (2) Required tools, etc. for discharging the drive battery
 - (3) Safety measures at the accident site
 - (4) Initial response at the accident site

 5. Preparation of rescue operation
 - (1) Preparation
 - (2) Case-A1: It is not necessary to cut the vehicle body and the high voltage components are intact
 - (3) Case-A2: It is necessary to cut the vehicle body, but immediate rescue is not essential (About 10 minutes are required before actual rescue work can begin.). Alternatively, the orange-coloured high voltage cables are exposed.
 - (4) Case-A3: It is necessary to cut the vehicle body and immediate rescue is essential or the orange-coloured high voltage cables are exposed

 6. Notes on how to handle the damaged vehicle
 - (1) Procedures to rescue passengers
 - (2) Case-B1: Vehicle fire
 - (3) Case-B2: Electrolyte leaks from the drive battery
 - (4) Case-B3: The drive battery is severely damaged
 - (5) Case-B4: Submerged vehicle
 - (6) Case-B5: Before righting a rolled over vehicle

 7. Vehicle specifications and precautions on how to transport the damaged vehicle
 - (1) Vehicle specifications
 - (2) If the vehicle can be driven
 - (3) Transportation of the accident vehicle by tow truck
 - (4) Towing by tow rope

1. Safety precaution for handling high voltage

The Outlander is equipped with a lithium-ion battery of max. voltage 300 V. This is used to activate the electric motor unit and some components such as air conditioning.

Before rescue work can begin, it is necessary to ensure “isolation” and “cut off” from the high voltage circuit in order to prevent the risk of electric shock before handling the vehicle.

Traction battery specification is “12kw/h lithium-ion, 300V”. Traction battery’s maximum voltage capacity is 336V when the Traction battery is being charged.

⚠ CAUTION;

Silence does not always mean that the hybrid system is turned off.

Ensure that the high voltage circuit is “isolated” or “cut off”.

(1) Isolation from the high voltage circuit

1) The high voltage circuit is insulated from the vehicle body.

2) All of high voltage components are covered up by cases and covers.

Note that high voltage wiring cables can be distinguished from normal wiring harness by their orange coloured insulation.

3) The cases and covers are insulated from the high voltage circuit inside.

(2) Disconnection of the high voltage circuit

This vehicle has a system which allows the high voltage current supplied from the drive battery to be isolated automatically if you cannot isolate the high-voltage system due to service maintenance or an accident.

The high-voltage circuit will be isolated by pulling the charging connector during the battery charging.

<Disconnection mode>

System \ Case	Manual mode		Automatic mode	
	Charging connector	Service plug	Electric motor switch linked	Collision sensing
Normal usage	N/A	N/A	Available	N/A
During inspection or maintenance	N/A	Available	Available	N/A
Collision accident	N/A	N/A	N/A	Available
During the battery charging	Available	N/A	N/A	N/A

(3) Precautions when rescuing passengers

⚠ WARNING;

Failure to follow these instructions may result in serious injury such as electric shock:

(1) This vehicle is equipped with a high-voltage system of max. operation voltage 336V.

(2) The possibility of a high volume electrolyte leak as a result of the drive battery damage is reduced by the design inside the drive battery.

(3) Drive battery uses an electrolyte made of flammable “Carbonate ester solution of lithium salts”. When reacting with moisture in the air, this electrolyte generates acidic organic vapour which is harmful to human body.

Therefore, when handling this, please use appropriate Personal Protective Equipment (PPE) including mask for organic gas, solvent resistance gloves and eye protector and use appropriate caution.

(4) Vehicles with Mitsubishi remote control have an auxiliary battery (12 V) charging and a remote climate control functions. Therefore, even if the indicator in the electric motor switch is off, the high-voltage system may be active.

2. High-voltage component location

(1) High-voltage component and wiring harness locations

High voltage components and wiring cables are located as shown in the figure below.

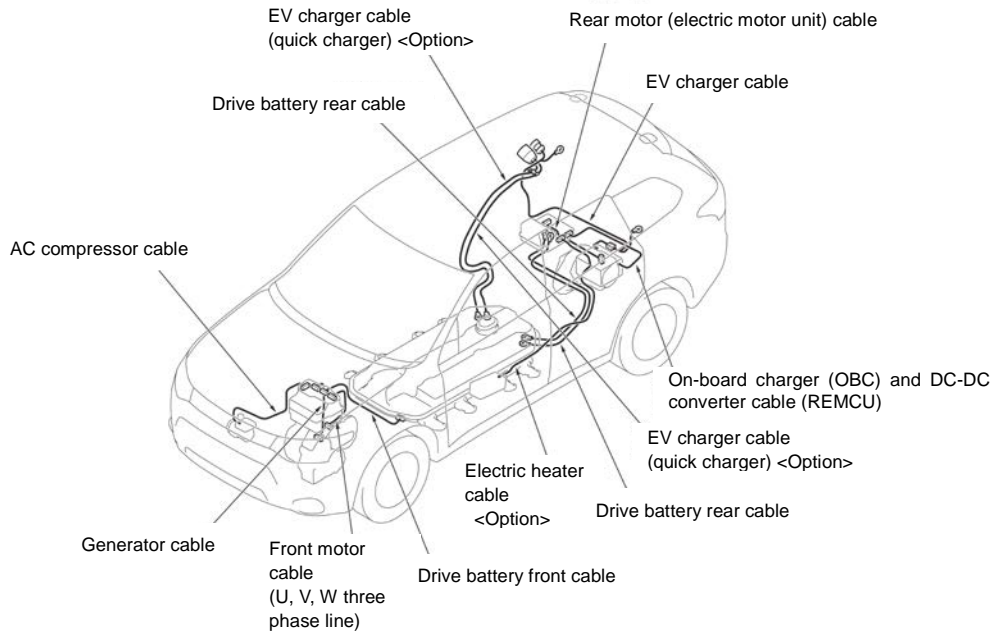

(2) SRS airbag system

SRS airbags system (location of airbags and related components) are located as show in the figure below:

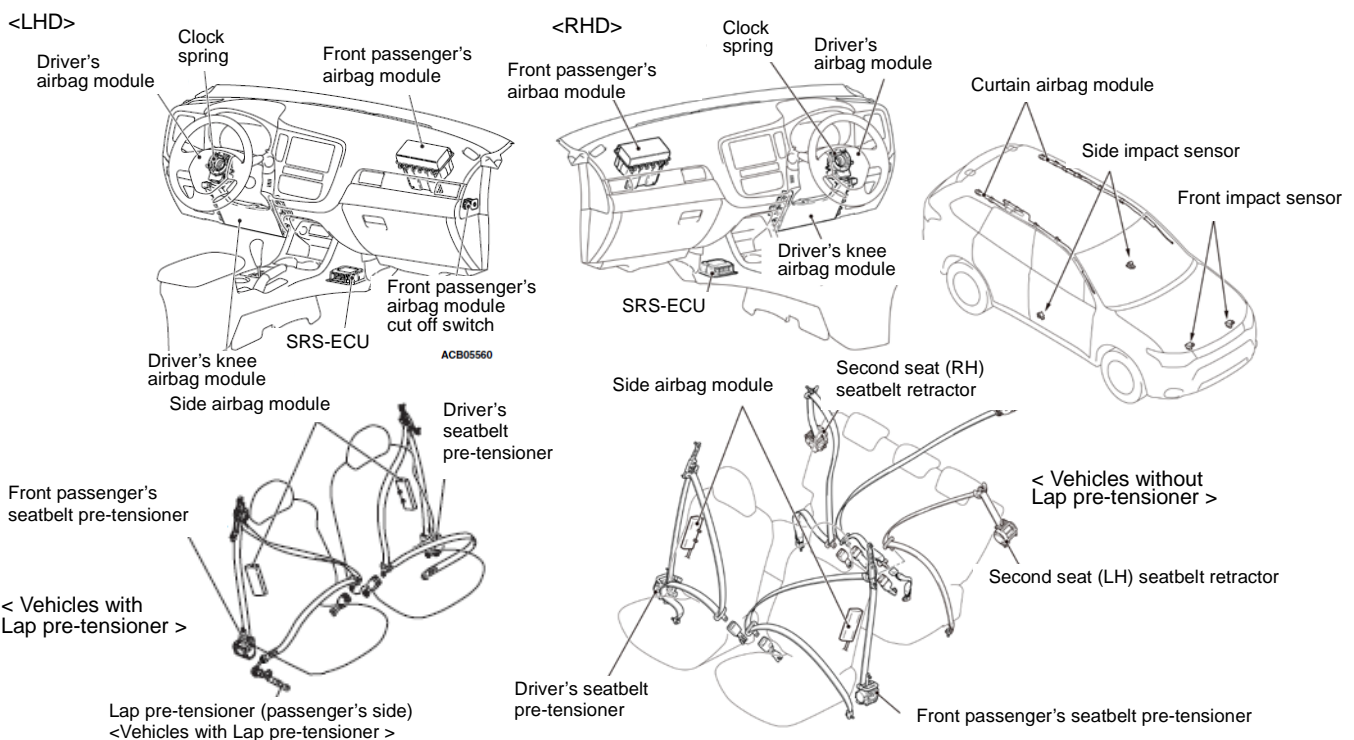
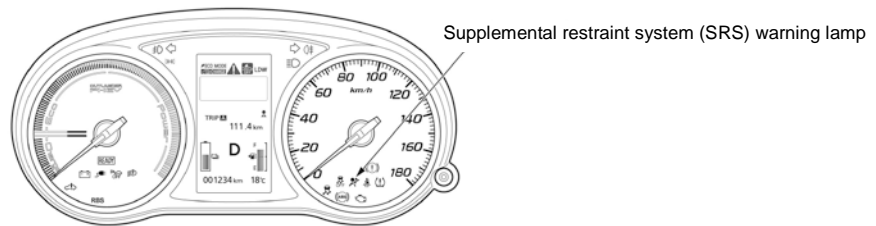

3. Features on vehicle exterior

Outlander PHEV shares one vehicle body with models with petrol engine. Therefore, their exteriors are very similar.

If you find any of the following features which can identify Outlander PHEV, always wear appropriate Personal Protective Equipment (PPE).

⚠ WARNING;

- Use insulating Personal Protective Equipment (PPE) (Rubber insulating gloves, Rubber soled insulating shoes: rated to a minimum of 400V voltage resistance), when contact with the vehicle body is possible, until you can identify whether the vehicle is Outlander PHEV or not.
- Engine noise does not always mean that the vehicle is a model with petrol engine. You should refer to the feature list.

(1) Feature list

"PHEV(PLUG-IN HYBRID EV)" logo, battery charging lid, chassis number (model code), power drive unit (PDU) cover

(2) Features on exterior

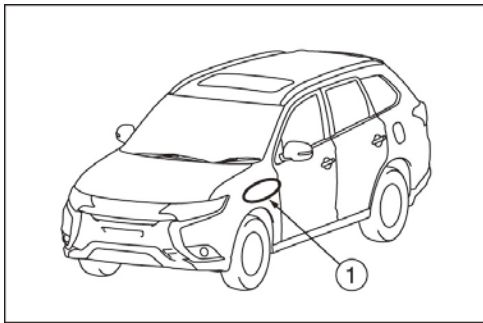

<Vehicles for Australia and New Zealand >

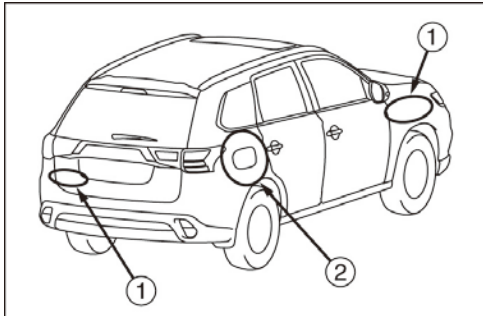

<Except for Australia and New Zealand >

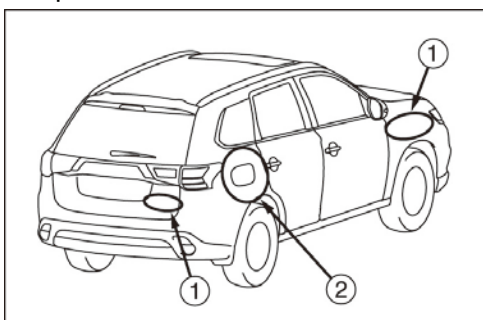

- ① PHEV(PLUG-IN HYBRID EV) logo
" PHEV(PLUG-IN HYBRID EV)" logos are fitted on the right and left fender panels and the tailgate.

<On fender>



<On tailgate>



- ② Charging lid (Right side of vehicle)

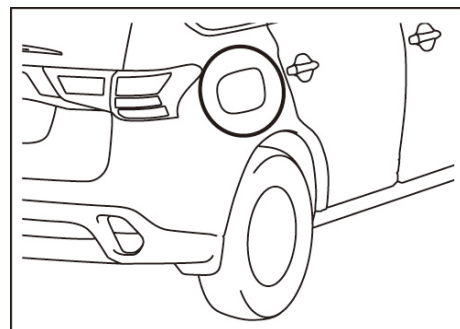

(3) Feature in the engine compartment and centre pillar

- ①, ② and ③: Chassis number is stamped on the hood, the centre pillar and the cowl top panel
- ④ "PLUG-IN-HYBRID EV" logo

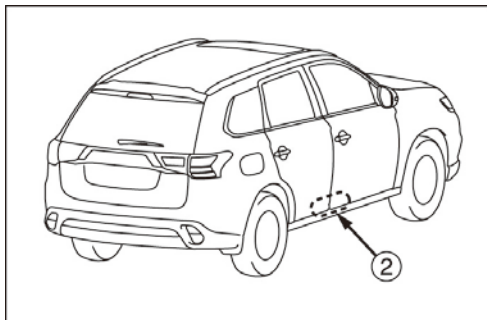
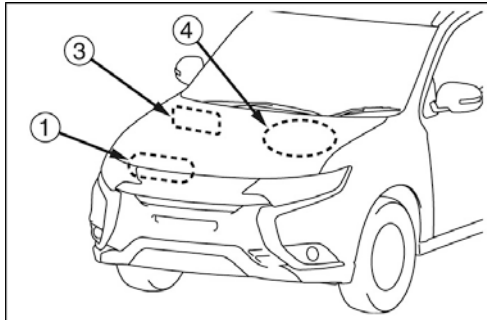

① Vehicle information code plate
 The vehicle information code plate is riveted to the hood.
 OUTLANDER-PHEV includes "GG2W" in the MODEL code.
 Ex) Model code stamp :

Europe :
GG2WXDHHZR6
Australia and New Zealand :
GG2WXDHHZR8

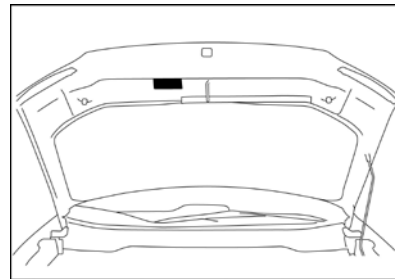

② Manufacture's Plate
 The Manufacture's plate is riveted to the face of the center pillar of right side.
 OUTLANDER-PHEV includes "GG2W" in the Chassis number.
 Ex) Chassis number stamp:

Europe :
JMAXDGG2WEZ000001
JMBXDGG2WEZ000001
Australia and New Zealand :
 —

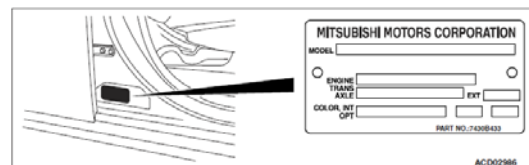

- ③ Stamped chassis number
The chassis number is stamped on the right side of the front deck in the engine compartment.

OUTLANDER-PHEV includes "GG2W" in the Chassis number.

Ex) Chassis number stamp:

Europe :

JMAXDGG2WEZ000001

JMBXDGG2WEZ000001

Australia and New Zealand :

JMFXDGG2WEZ000001

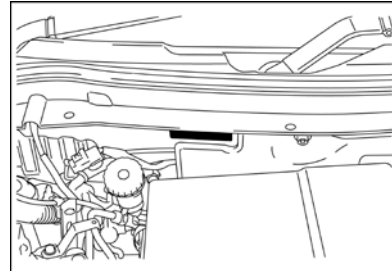

- ④ "PLUG-IN-HYBRID EV" logo
If "PLUG-IN-HYBRID EV" logo is shown on the power drive unit (PDU) cover, the vehicle must be Outlander PHEV.



4. What is necessary at the accident site

You have to observe the followings:

(1) Required tools, etc. at the accident site

The items marked by ★ are essential. The other items should be available and used as necessary.

- 1) ★Protective clothing (rated to a minimum of 400 V voltage resistance)
 - Rubber insulating gloves and rubber soled insulating shoesProtects service technician from high voltage.
- 2) ★Open-end wrench (10 x 12 mm)
 - Use this tool to disconnect the negative terminal (10 mm) of the auxiliary battery (12 V).
 - Use this tool to remove the service lid mounting nuts when the service plug is pulled out.
- 3) Mask for organic gas, solvent resistance gloves (or rubber-adhered gloves) and eye protection
If electrolyte leaks from the drive battery, it may generate acidic organic vapour. Mask for organic gas, solvent-resistant gloves and eye protection (safety glasses) should be used when you handle the electrolyte.
- 4) Absorption mat and/or sand
Use to absorb the electrolyte, fuel or oil.
Commercially available absorption mat can be used not only for oil or fuel but also the electrolyte.
- 5) Fire extinguisher
Use a fire extinguisher which is suitable for flammable liquid and electrical equipment fires.
- 6) Insulating plastic tape
Use to isolate exposed high voltage wiring and/or tool.

(2) Required tools, etc. for discharging the drive battery

The drive battery is severely damaged

- 1) Easy set pool and leak-proof thick plastic sheet (as necessary)
Prepare an easy set pool with a minimum size of approximately 550 cm x 250 cm x 100 cm (length x width x height). Discharge the drive battery by soaking the entire vehicle in water.
- 2) Wrench (12 mm)
The service hole lid must be removed to drain the water inside the drive battery

The drive battery is not damaged

- 1) MB992947: RUBBER, DRAIN PLUG
Silicone rubber sheet: approximately 70 x 70 x 3 mm.
Use to seal the drain plug.
- 2) MB992946: COVER, DRAIN PLUG
Use as a base plate for the silicone sheet.

(3) Safety measures at the accident site

⚠ WARNING;

Use insulating Personal Protective Equipment (PPE) (Rubber insulating gloves, Rubber soled insulating shoes: rated to a minimum of 400V voltage resistance) when you may touch the vehicle body directly or indirectly.

- 1) Always wear appropriate Personal Protective Equipment (PPE).
- 2) Never directly touch any exposed orange-coloured high voltage wiring cables (cutoff or break a plastic jacket), or high voltage components that might be damaged.
- 3) If fluid leakage is observed under the body, the fluid may be electrolyte leaking from the drive battery.

(The electrolyte is clear and colourless and with a slightly sweet odour. It has similar viscosity to water.)

Wear mask for organic gas, solvent-resistant gloves (or heavy-duty rubber gloves) and eye protection (safety glasses). Use an absorption mat or sand to absorb spilled electrolyte.

This electrolyte is flammable and poisonous acid gas will evaporate from electrolyte.

⚠ WARNING;

Mask for organic gas, solvent-resistant gloves (or heavy-duty rubber gloves) and eye protection (safety glasses) should be worn if electrolyte leaks from the drive battery.

If electrolyte comes into contact with your skin, flush with immediately.

If electrolyte gets into your eyes, do not rub your eyes. Immediately flush your eyes with a large quantity of water and seek medical treatment as soon as possible.

If you feel sick by inhaling the electrolyte vapour, take a rest in a well-ventilated area and seek medical treatment as soon as possible.

- 4) If a high voltage component or wiring is suspected to be damaged, follow 5-(3) "It is necessary to cut the vehicle body, but immediate rescue is not essential" to isolate high voltage as much as possible.

For locations of high voltage components and wiring harness, refer to 2-(1) and (2).

⚠ CAUTION;

If the damaged vehicle must be left unattended, display a sign indicating "HIGH VOLTAGE WORK IN PROGRESS!! DANGER! DO NOT TOUCH!". Refer to the signboard example at the end of this manual.

Reference) Fluids used in this vehicle

Unit name	Designation	Colour
Engine to fuel tank	Petrol	Light orange
Engine	Engine oil	Dark brown
Electric motor and generator	CVT fluid	Blue-green
Transaxle (transmission)	ATF	Red
Cooling fluid	Coolant	Blue-green
Heater fluid	Coolant	Blue-green
Brake	Brake fluid	Clear & colourless
Drive battery	Electrolyte	Clear & colourless
12V auxiliary battery	Electrolyte	Clear & colourless

(4) Initial response at the accident site

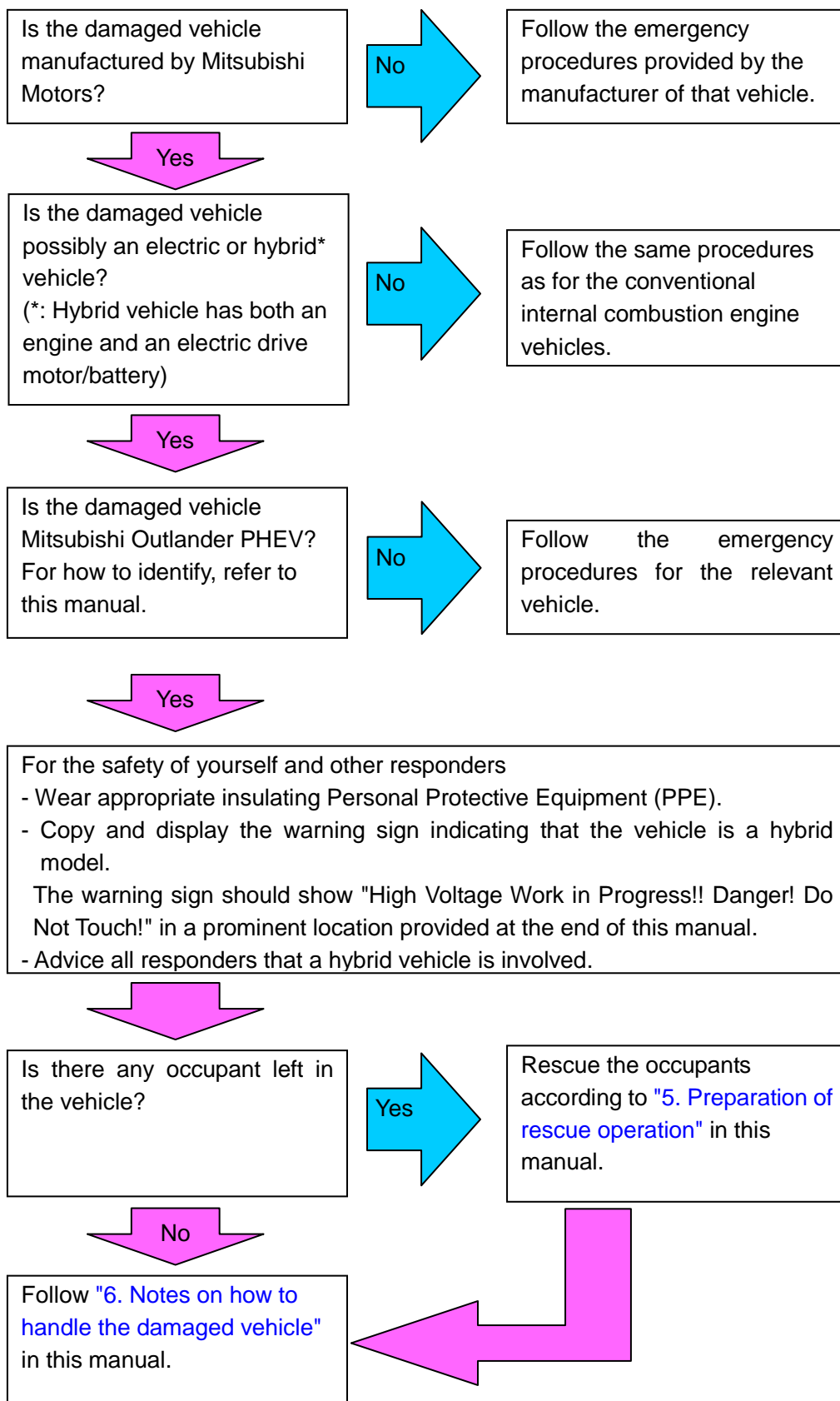

5. Preparation of rescue operation

Failure to follow these instructions may result in serious injury such as electric shock. Do not touch high voltage wires or components. Isolate high voltage circuits as necessary.



WARNING;

Use insulating Personal Protective Equipment (PPE) (Rubber insulating gloves, Rubber soled insulating shoes: rated to a minimum of 400V voltage resistance) when you may touch the vehicle body directly or indirectly.

(1) Preparation

- Always approach vehicle from the sides to stay out of potential travel path. It may be difficult to determine whether the vehicle is ready to start as the EV driving mode does not generate any engine noise.
- Always obtain the key (remote key) from the person who you should rescue. He or she may be carrying it in a pocket or purse. The vehicle cannot be moved without the key (remote key)
- Activate the electric parking lock (turn on the electric parking switch or turn off the electric motor switch). Then apply the parking brake and position chocks under front and rear wheels.
- Alert other road users of an emergency by activating the hazard warning lamps, etc.
- Move the key (remote key) away from the vehicle to prevent unintended start-up of the system by inadvertent contact with a switch or damage from the crash.
- On vehicles with Mitsubishi remote control, any of the systems (12V auxiliary battery charging or remote climate control) may be activated inadvertently, causing high voltage. Therefore, prior to any service operation, disconnect the negative terminal of the 12V auxiliary battery.
- The system will be deactivated if the hood, the doors or the tailgate is opened while the 12V auxiliary battery charging or remote climate control is activated.



CAUTION;

When the 12V auxiliary battery is disconnected or removed, do not close the tailgate. If you close it once, you cannot open it again.

Procedures to rescue passengers

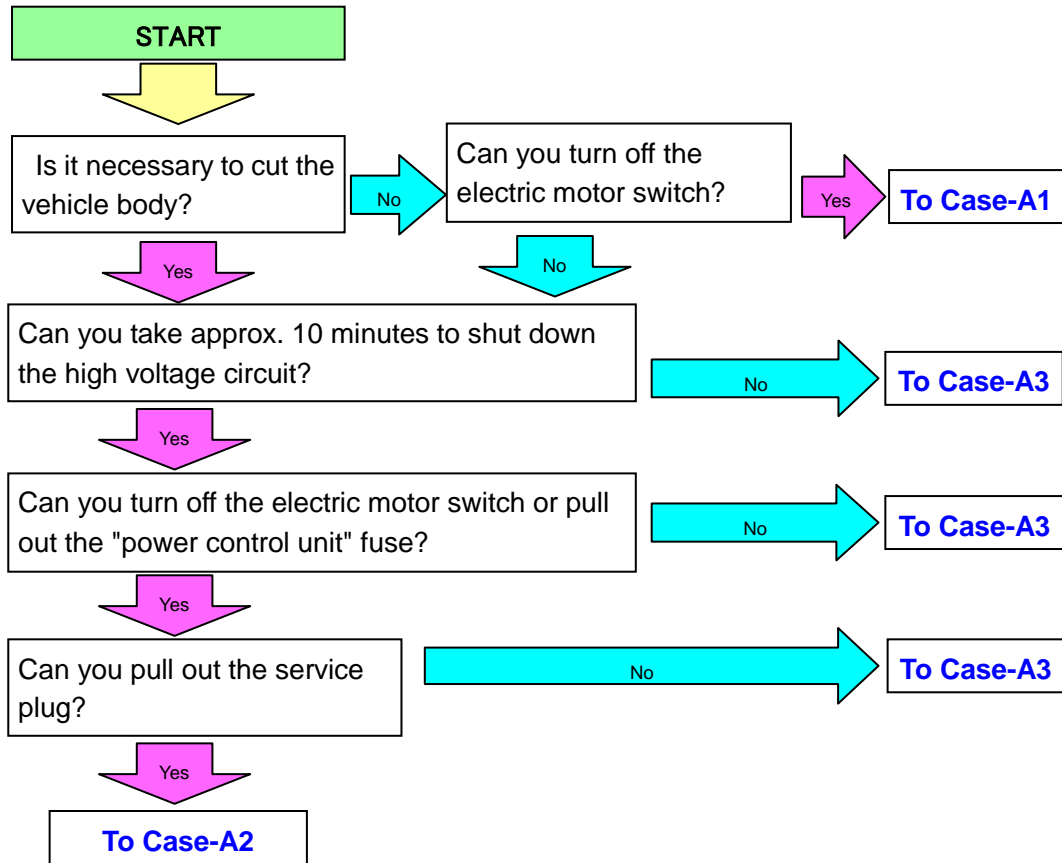

(2) Case-A1:

It is not necessary to cut the vehicle body and the high voltage components are intact

Orange-coloured wiring cables indicate high voltage components.

Confirm that no high voltage wires are exposed, and then turn off the electric motor switch to rescue passengers.

If the window glasses or the doors must be removed, observe the same procedure as for the conventional models.

- ① Turn off the electric motor switch by pressing it.

Confirm that the indicators in the electric motor switch and the ready indicator in the instrument are turned off.

<LHD>

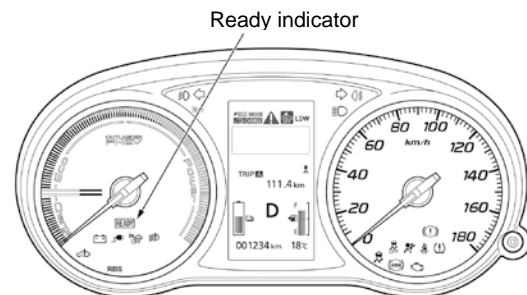
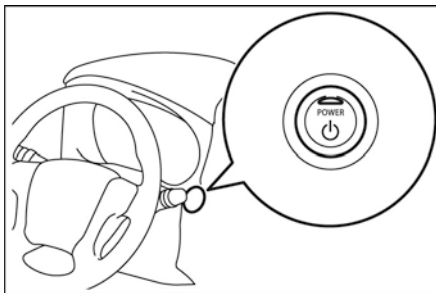

<RHD>

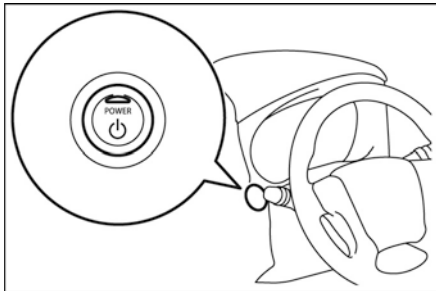

⚠ CAUTION;

If the orange-coloured high voltage wires are exposed, follow **Case-A2** to take actions.

If it is necessary to cut the vehicle body, follow **Case-A2** or **Case-A3** to take actions.

(3) Case-A2:

It is necessary to cut the vehicle body, but immediate rescue is not essential (About 10 minutes are required before actual rescue work can begin.).
Alternatively, the orange-coloured high voltage cables are exposed.

1) Carry out any of the following two operations:

This will disconnect the high-voltage electric current supplied from the drive battery.

① Turn off the electric motor switch by pressing it.

Confirm that the indicators in the electric motor switch and the ready indicator in the instrument are turned off.

<LHD>

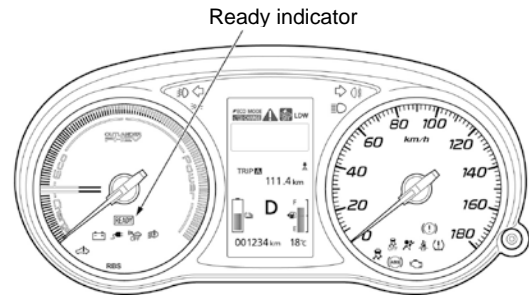
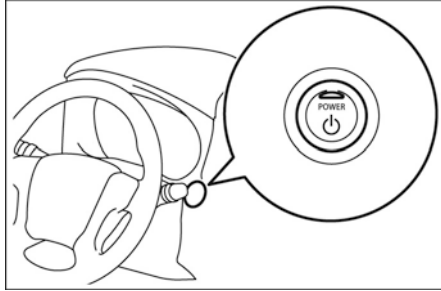

<RHD>

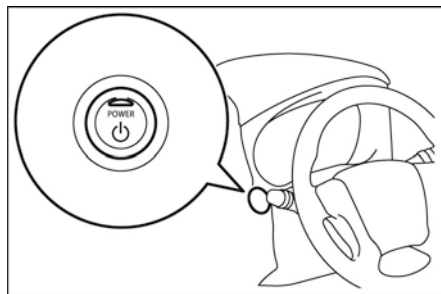

② Remove "Power unit control" fuses (10A, terminal F7 in the illustration below) from the engine compartment fuse box.

If you cannot locate this fuse, remove all fuses and relays in the fuse box.

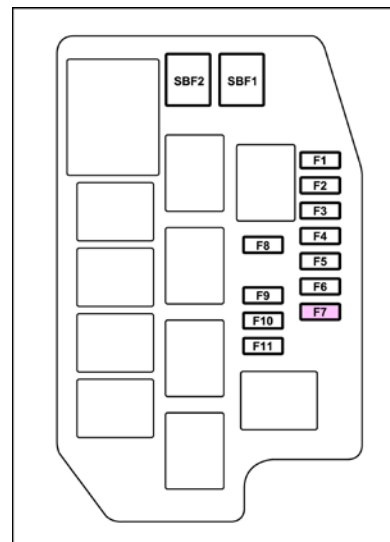
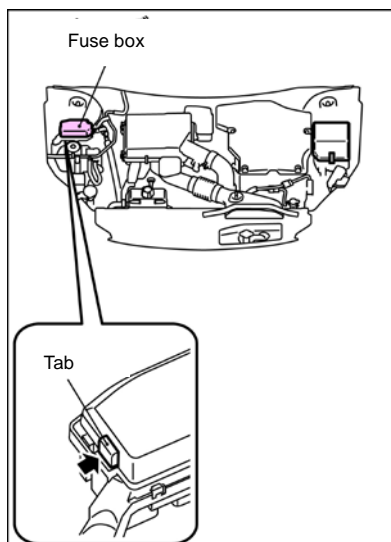

- 2) Wait at least one minute before proceeding to the next step.
Hybrid system will be deactivated during this waiting time.

⚠ WARNING;

The condenser in the SRS-ECU retains the voltage required for deploying the air bags for approx. one minute. If you start the service operation before that one minute elapses, the air bags may be deployed, causing serious injuries.

- 3) Disconnect the 12V auxiliary battery negative terminal.
(Shut down the power supply to the SRS airbag system.)

How to disconnect the 12V auxiliary battery negative terminal

Use an open end wrench (10 mm) to disconnect the negative terminal of the 12V auxiliary battery according to the procedure below, and then wrap a plastic tape around the disconnected negative terminal.

Shut down the SRS air bag system circuit by disconnecting the negative terminal of the 12V auxiliary battery.

- ① Pull up the strap on the luggage floor box.
- ② Remove the service lid of the 12V auxiliary battery.

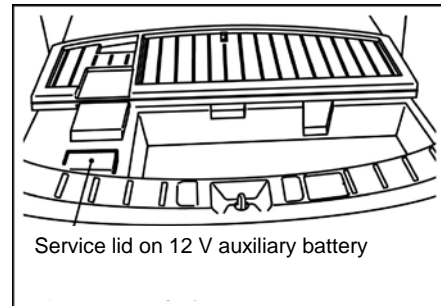
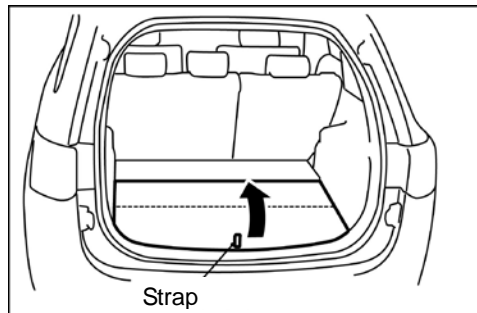

- ③ Disconnect the 12V auxiliary battery negative terminal.

- 4) Wait at least five minutes before proceeding to the next step.

⚠ WARNING;

Some components or wires can retain high voltage for five minutes.
Before cutting the high voltage components or wires, observe precautions on cutting the vehicle body to remove the service plug.

- 5) Wear insulating Personal Protective Equipment (PPE) to remove the service plug.
(Shut down the high voltage circuit in the drive battery)

⚠ WARNING;

Always wear Personal Protective Equipment (PPE) when pulling out the service plug.

•How to pull out the service plug

Wear Personal Protective Equipment (PPE) and observe the procedure below to remove the service plug.

Pulling out the service plug will shut down the high voltage circuit in the drive battery.

- ① Remove the service lid cover in the footwell under the middle of the second seat. (four clips)
Use a 10-mm open end wrench to remove the service lid. (four nuts)

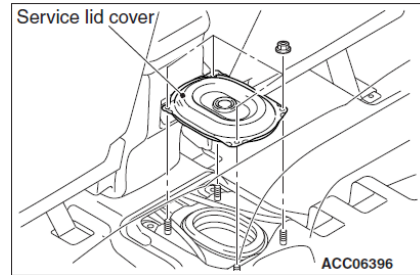
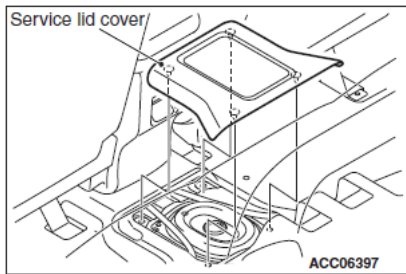

- ② Wear Personal Protective Equipment (PPE) and remove the service plug.
 - Release the lock lever on the service plug.
 - Raise the service plug lever.
 - Remove the service plug by pulling it upward.

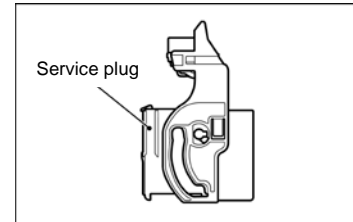
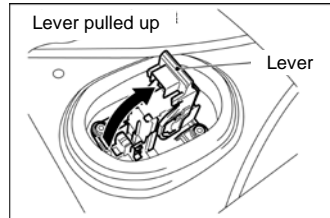
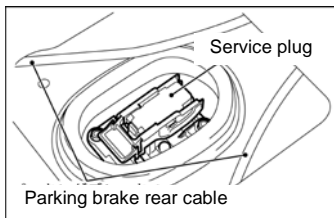

- 6) Start cutting the vehicle body.
 - Do not cut in vicinity of the drive battery (see the illustration below).

Coloured portion: drive battery

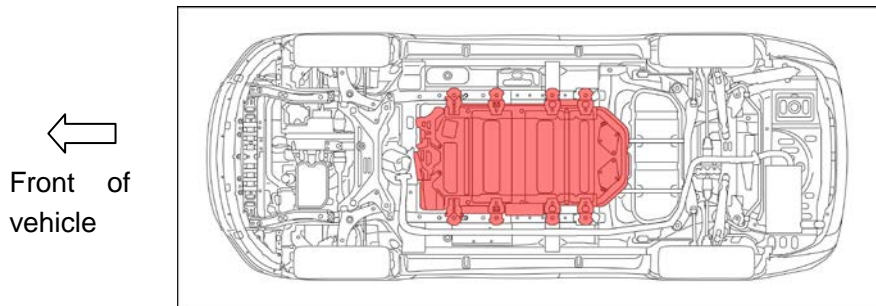

Bottom

⚠ WARNING;

- Always observe the specified procedure to remove the service plug. If you do not observe the procedures described in this section to remove the service plug, a short circuit can occur and melted metal debris may fly from the service plug terminal, resulting in injury to rescuers and/or vehicle occupants.
- After removing the service plug, keep it in a secure place away from other rescue workers to prevent accidental handling/re-installation of the service plug.
- NEVER cut the drive battery.
- Use a hydraulic cutter or a suitable tool which does not generate sparks to cut the vehicle body. If you fail to do this, you or the passengers may be seriously injured.

(4) Case-A3:

It is necessary to cut the vehicle body and immediate rescue is essential or the orange-coloured high voltage cables are exposed

- Preliminary confirmation

Read this page and "2. High voltage component location" before cutting the vehicle body.



⚠ WARNING;

Use a hydraulic cutter or a suitable tool which does not generate sparks to cut the vehicle body. If you fail to do this, you or the passengers may be seriously injured. Never touch any exposed orange-coloured high voltage wiring cables (cutoff or break a plastic jacket), or the portions shown in the figure.

• Precautions on cutting the vehicle body

⚠ WARNING;

NEVER cut the drive battery.

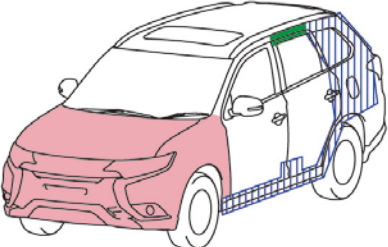
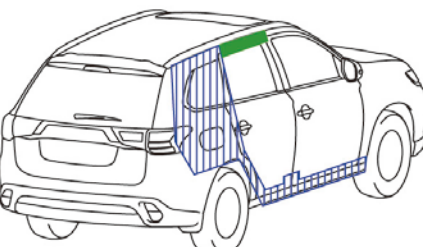
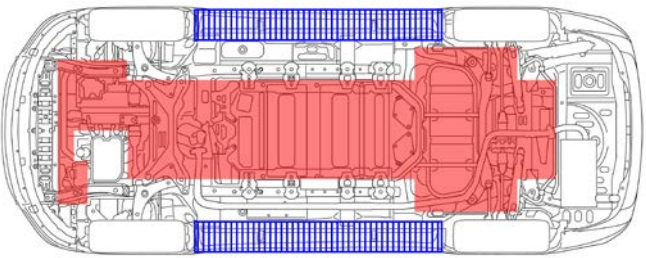
	<p><u>Risk of high voltage shock</u> Never cut this area in vicinity of the high voltage components and cables as an electric shock may occur.</p>
	<p><u>Risk of curtain airbag deployment</u> Do not cut this area because high pressure gas will be generated to deploy a curtain airbag. If the curtain airbag have already been deployed, it can be cut.</p>
	<p><u>Risk of airbag deployment</u> Do not cut this area because there is risk that an airbag may be deployed due to a short circuit or an impact caused by the accident. If an airbag has already been deployed, this area can be cut. If at least one minute has elapsed after disconnecting the negative terminal of 12V auxiliary battery or turning off the ignition switch, this area can be also cut.</p>
<div data-bbox="284 1346 785 1671"></div> <div data-bbox="826 1346 1327 1671"></div> <div data-bbox="290 1800 418 1921"><p>← Front of vehicle</p></div> <div data-bbox="450 1704 1161 2007"></div> <p data-bbox="753 2018 906 2042">Bottom view</p>	

6. Notes on how to handle the damaged vehicle (1) Procedures to rescue passengers

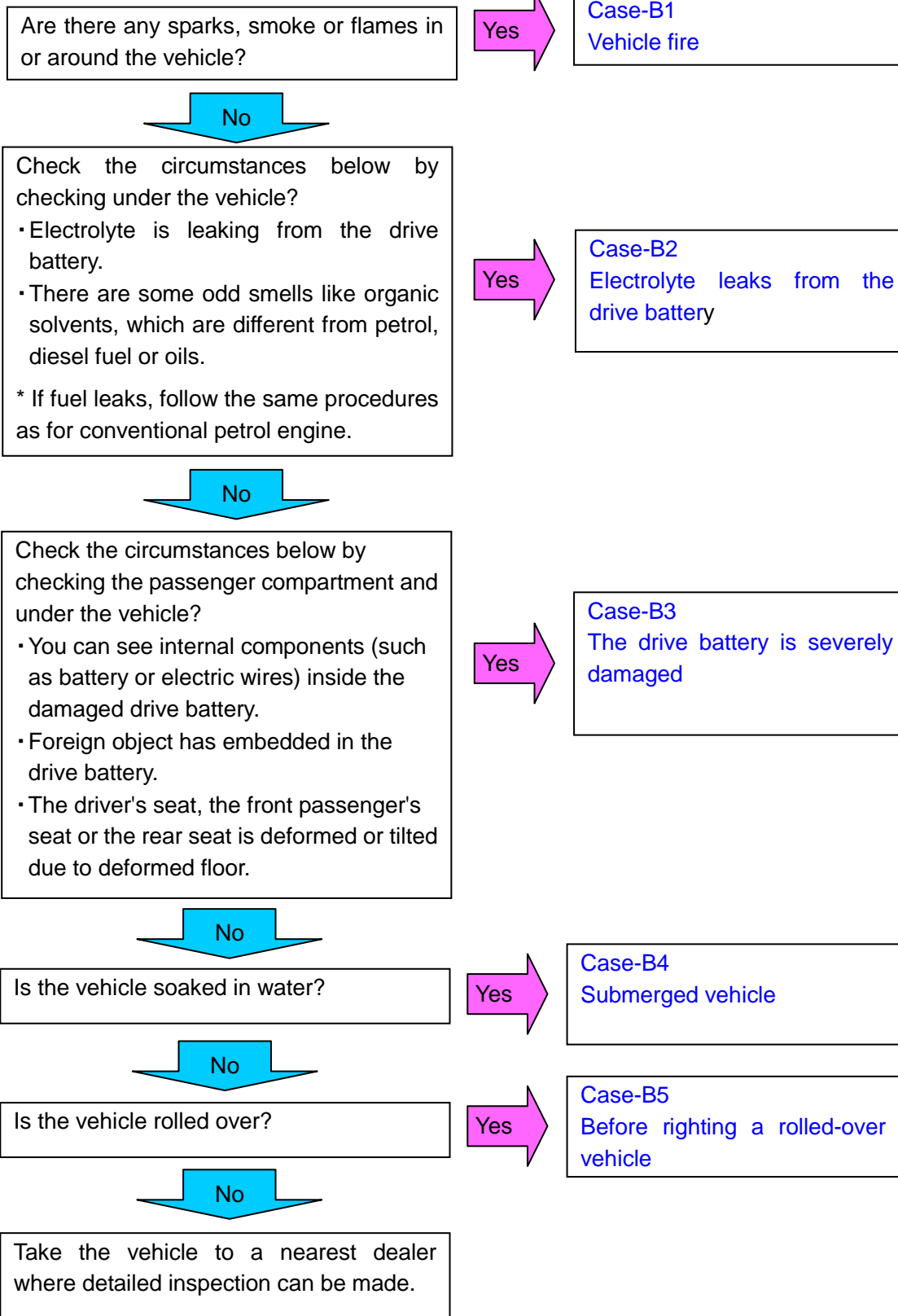

(2) Case-B1:

Vehicle fire

In case of vehicle fire, alert fire department immediately and start extinguishing the fire using the following procedures where possible.

CAUTION;

Failure to follow these instructions may result in serious injury such as electric shock:

- 1) The drive battery is designed to prevent a substantial amount of electrolyte from leaking from the drive battery just in case it is broken.
- 2) The drive battery uses an electrolyte made of flammable "Carbonate ester solution of lithium salts".

When reacting with moisture in the air, this electrolyte generates acidic organic vapour which is harmful to human body.

Therefore, when handling this, please use appropriate Personal Protective Equipment (PPE) including mask for organic gas, solvent resistance gloves and eye protector and use appropriate caution.

1) Fire extinguishing procedure

WARNING;

Never use seawater or any water containing salt.

① By using fire extinguisher

Use a fire extinguisher which is suitable for flammable liquid and electrical equipment fires.

② By using water

Use water not containing salt, such as tap water, well water or pond water. **DO NOT** attempt to extinguish the fire with a small amount of water as it is dangerous.

A large volume of water, such as from a fire hydrant must be used. Unless a large volume of salt-free water is available, keep away from the vehicle fire and wait for fire department to arrive.

2) Procedures after the fire is extinguished

The drive battery must always be discharged (de-energised) after the vehicle fire is extinguished.

Follow the instructions in [Case-B3 "The drive battery is severely damaged"](#) to discharge the drive battery.

WARNING;

The following potential dangers exist until the drive battery (lithium-ion battery) is properly discharged.

- There is a potential for delayed ignition or re-ignition of the lithium-ion battery even after it is believed to be extinguished.
- If you detect some odd smells, the inside of the drive battery may be ignited. If you hear gurgling, burbling, hissing or popping noise in vicinity of the high voltage battery even after fire is extinguished, the battery is still ignited. Alert fire department immediately and open windows to avoid potential flammable hydrogen gas if possible.

(3) Case-B2:

Electrolyte leaks from the drive battery

⚠ CAUTION;

Failure to follow these instructions may result in serious injury such as electric shock:

- 1) The drive battery is designed to prevent a substantial amount of electrolyte from leaking from the drive battery just in case it is broken. However, if you handle the battery improperly, serious injury such as electric shock may be caused.
- 2) The drive battery uses an electrolyte made of flammable "Carbonate ester solution of lithium salts".

When reacting with moisture in the air, this electrolyte generates acidic organic vapour which is harmful to human body.

Therefore, when handling this, please use appropriate Personal Protective Equipment (PPE) including mask for organic gas, solvent resistance gloves and eye protector and use appropriate caution.

- 1) Always wear insulated Personal Protective Equipment (PPE).
- 2) Never directly touch any exposed orange-coloured high voltage wiring cables (cutoff or break a plastic jacket), or high voltage components that might be damaged.
- 3) If electrolyte leaks from the drive battery, it may generate acidic organic vapour. Therefore, wear mask for organic gas, solvent-resistant gloves (or heavy-duty rubber gloves) and eye protection (safety glasses). Use an absorption mat or sand to absorb spilled electrolyte. This electrolyte is flammable and poisonous acid gas will evaporate from electrolyte. (The electrolyte is clear and colourless and with a slightly sweet odour. It has similar viscosity to water.)

⚠ CAUTION;

Used absorption mat or sand shall be properly disposed of as an industrial waste according to local regulations.

- 4) After you take measures to prevent the electrolyte from spreading or avoid the fire, the drive battery must be discharged.
Follow the instructions in [Case-B3 "The drive battery is severely damaged"](#) to discharge the drive battery.

(4) Case-B3:

The drive battery is severely damaged

If the drive battery is severely damaged, the drive battery must be discharged to avoid electric shock and fires.

Follow the instruction below to discharge the drive battery.

⚠ CAUTION;

Failure to follow these instructions may result in serious injury such as electric shock:

- The drive battery is designed to prevent a substantial amount of electrolyte from leaking from the drive battery just in case it is broken. However, if you handle the battery improperly, serious injury such as electric shock may be caused.
- The drive battery uses an electrolyte made of flammable "Carbonate ester solution of lithium salts".

When reacting with moisture in the air, this electrolyte generates acidic organic vapour which is harmful to human body.

Therefore, when handling this, please use appropriate Personal Protective Equipment (PPE) including mask for organic gas, solvent resistance gloves and eye protector and use appropriate caution.

- Physical damage to the vehicle or the drive battery may result in immediate or delayed release of toxic and/or flammable gases and fire.

- 1) Transport the vehicle on a flatbed truck to a nearest dealer or an open space large enough to prevent fire from spreading in case of a vehicle fire. (For vehicle loading procedures, refer to [6-\(3\) "Transporting a damaged vehicle"](#))
- 2) After the damaged vehicle is loaded on a flatbed truck, inspect for leaking electrolyte from the vehicle. If you find any leakage, use an absorption mat or sand to absorb spilled electrolyte to prevent it from spreading further.
- 3) Carry a fire extinguisher during transportation in case of fire. For enhanced safety, always have a tow truck loaded with a damaged vehicle followed by another support vehicle for monitoring.
- 4) After transportation, discharge the battery immediately.
- 5) If it is not possible to proceed to the drive battery discharging procedures immediately, place the vehicle in an open space away from any structure or vehicle, and continue to monitor the vehicle until the discharging procedures are completed and the risk of fire is eliminated.

⚠ WARNING;

If you detect some odd smells, the inside of the drive battery may be ignited. If you hear gurgling, burbling, hissing or popping noise in vicinity of the high voltage battery even after fire is extinguished, the battery is still ignited. Alert fire department immediately and open windows to avoid potential flammable hydrogen gas if possible.

- If the battery is ignited, refer to [\(2\) Case-B1 Vehicle fire](#).

Discharging procedure:

⚠ WARNING;

Never fill seawater or any water containing salt.

This can result in sudden electrolysis, which generates a large volume of flammable hydrogen gas.

Electrolysis of water produces hydrogen inside the drive battery for approximately 84 hours after it is submerged in water.

To reduce the risk of fire, follow these instructions:

- Keep the vehicle in an outside well-ventilated area.
- Keep all windows, doors and tailgate open to prevent hydrogen from accumulating in the passenger compartment.

Items marked by ★ are required. The other items should be available and used as necessary.

Step 1. Set up an easy set pool in the size of approximately 550 cm x 250 cm x 100 cm (length x width x height).

Step 2. If there is a risk of water leakage from the easy set pool, place a thick plastic sheet under the pool.

Step 3. Use a forklift or similar equipment to place the vehicle in the centre of the pool.

⚠ CAUTION;

Place the vehicle horizontally or slightly tilted forward. If you fail to do this, the vehicle may not be submerged up to the required level.

Step 4. Remove the service lid cover in the footwell under the middle of the second seat.
(four clips)

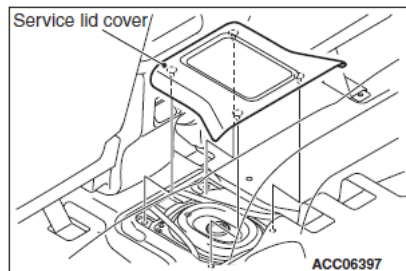

Step 5. Remove the plug on the service lid.

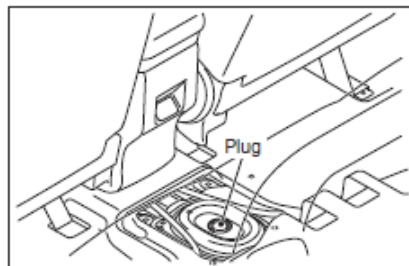

Step 6 ★. Open the doors.

Step 7 ★. Make sure to use water not containing salt, such as tap water, well water or pond water, to prevent harmful reactions.

Keep pouring a sufficient volume of water, such as from a fire hydrant or a tap. DO NOT attempt to extinguish the fire with a small amount of water.

Required water level: Keep pouring water until the entire floor is submerged (a minimum required depth of 50 cm is achieved; see illustration below.) This water level is considered deep enough for the drive battery to be completely submerged in water.

If the vehicle body significantly deformed due to impact from crash, make sure that the drive battery installed under the floor is completely submerged in water.

Maintain this water level for at least 84 hours (3.5 days) with the drive battery submerged in water. Check the water level periodically. When the water level is lower than the specified level, add fresh water.

Reference) Water filling amount in the easy set pool

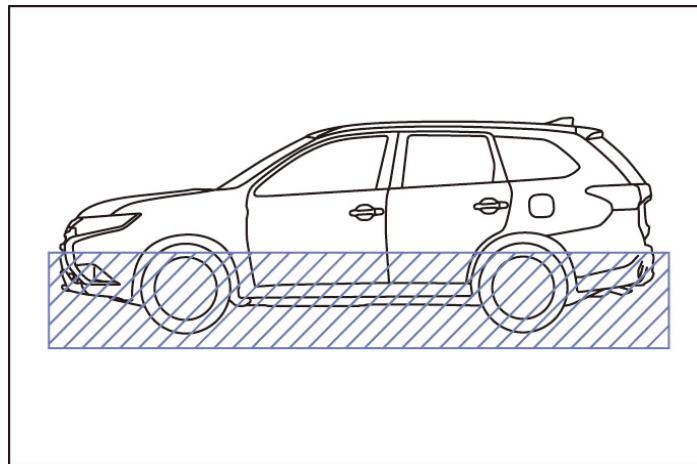

Until the entire floor is submerged
(until the service plug is submerged
completely)

How to drain water from the drive battery:

Step 1. Wait for at least approx. 84 hours (3.5 days), and then drain water from the pool.

Step 2. Use a 12-mm wrench to remove the service hole lids on the bottom of the drive battery and drain the drive battery.

⚠ CAUTION;

- To drain the drive battery, always observe the specified procedure (removal of the service hole lids).
- The water drained from the pool and the drive battery shall be properly disposed of as an industrial waste according to local regulations.

Location of service hole lids for the drive battery.

The battery for a drive has two kinds of specifications.

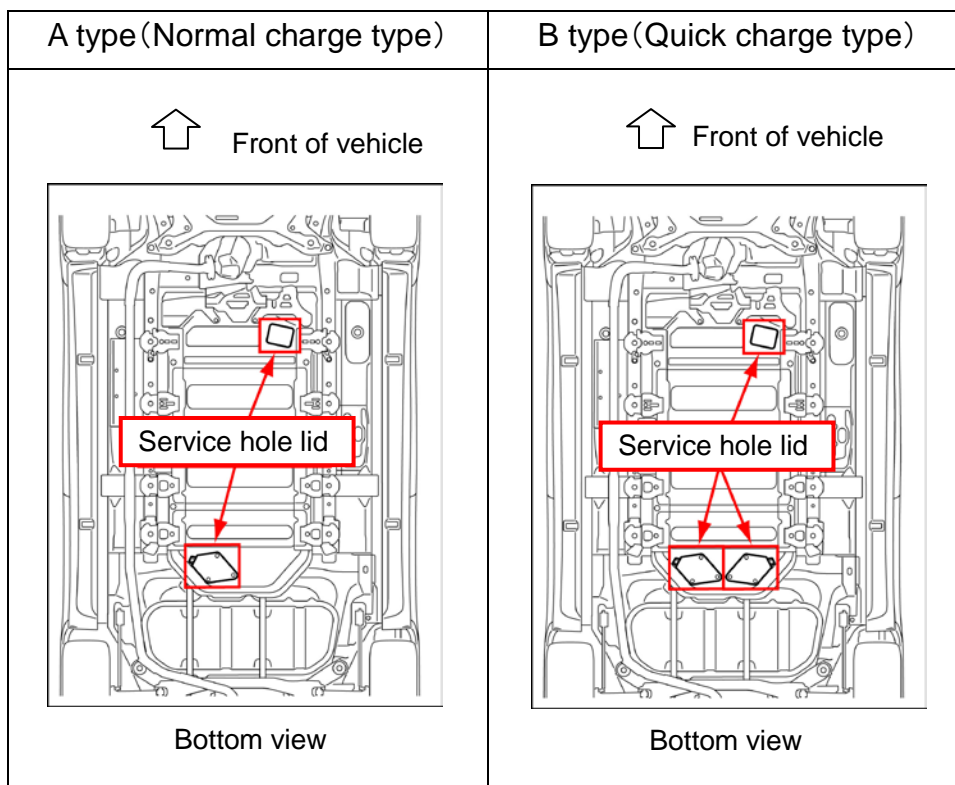

Removal of the service hole lid

- ① Removal of the earth bracket
- ② Removal of the service hole lid

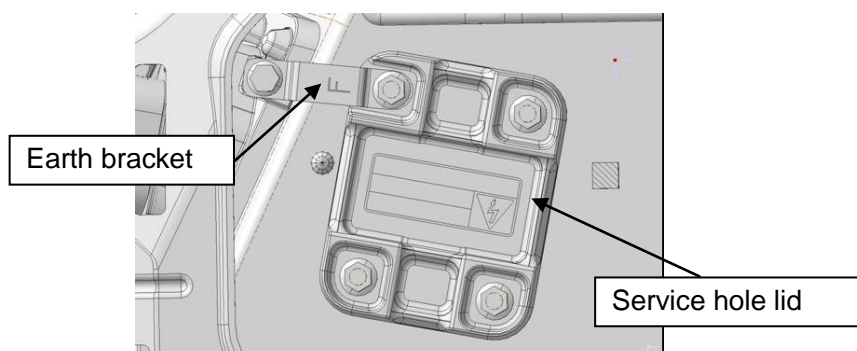

(5) Case-B4: Submerged vehicle

When a vehicle is submerged, there may be water ingress in the drive battery. Always follow the procedure below:

1) Procedure

① Rescue operation

Inspect the vehicle for damage.

If the vehicle is severely damaged, the drive battery is deformed, broken or exposed (or you cannot evaluate how severely the drive battery is damaged), wear insulated Personal Protective Equipment (PPE) and carry out the rescue operation while taking care not to touch the drive battery.

② Necessary action after the rescue operation

The drive battery is severely damaged

Submerge the drive battery into the pool immediately according to [Case-B3](#) and leave it submerged for approx. 84 hours (3.5 days).

The drive battery is not damaged

Fill water not containing salt, such as tap water, well water or pond water into the drive battery to discharge it.

CAUTION;

The water drained from the drive battery shall be properly disposed of as an industrial waste according to local regulations.

WARNING;

Never fill seawater or any water containing salt.

- This can result in sudden electrolysis, which generates a large volume of flammable hydrogen gas.
- If seawater may have entered the drive battery, fill water not containing salt strongly to drain the seawater from the drive battery.

Electrolysis of water produces hydrogen inside the drive battery for approximately 84 hours after it is submerged in water.

To reduce the risk of fire, follow these instructions:

- Keep the vehicle in an outside well-ventilated area.
- Keep all windows, doors and tailgate open to prevent hydrogen from accumulating in the passenger compartment.

2) How to fill water into the drive battery

- ① Remove the service lid cover in the footwell under the middle of the second seat.
(Four clips)

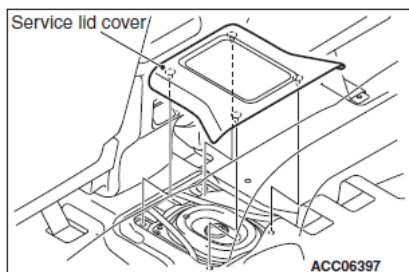

- ② Remove the plug on the service lid.

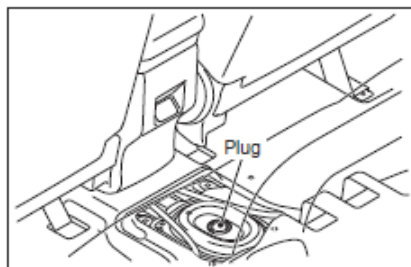

- ③ Fill water not containing salt, such as tap water, well water or pond water through the plug opening on the service lid fully. Then continue pouring at a rate of 3 litre/min for 30 minutes to remove foreign materials from the inside of the battery. Use a suitable tray to collect the poured water through the drain plug at the bottom of the drive battery.

(You cannot see the drain plug because it is covered with the battery protector as shown)

↑ Front of vehicle

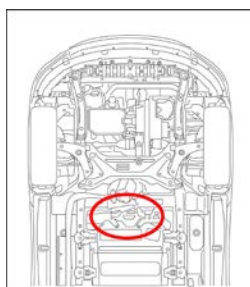

Bottom view

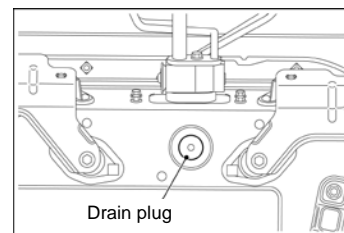
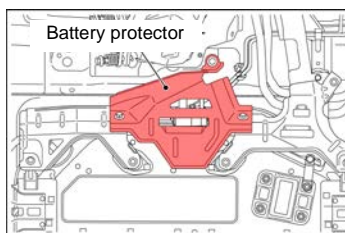

⚠ CAUTION;

The water drained from the drive battery shall be properly disposed of as an industrial waste according to local regulations.

- ④ Wait for approx. 20 minutes until the water is drained completely.
- ⑤ Raise the vehicle and then use a 12-mm wrench to remove the battery protector.
- ⑥ Move the vehicle to an outside well-ventilated area.
- ⑦ Place the drain plug rubber (MB992947) and the drain plug cover (MB992946) in

that order on the bottom of the drain plug. Then hold them using a jack.

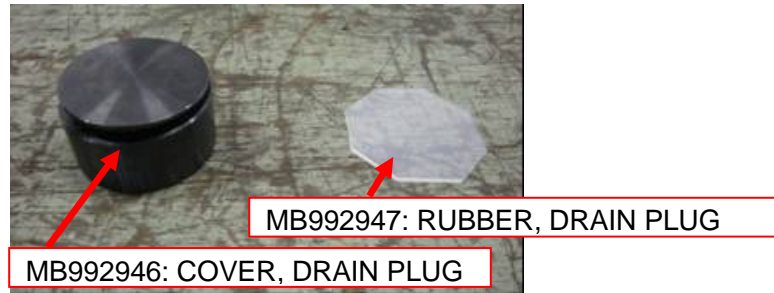

Reference) MB992947: RUBBER, DRAIN PLUG
Silicone rubber sheet: approx. 70 x 70 x 3 mm
MB992946: COVER, DRAIN PLUG
Base for the silicone rubber sheet

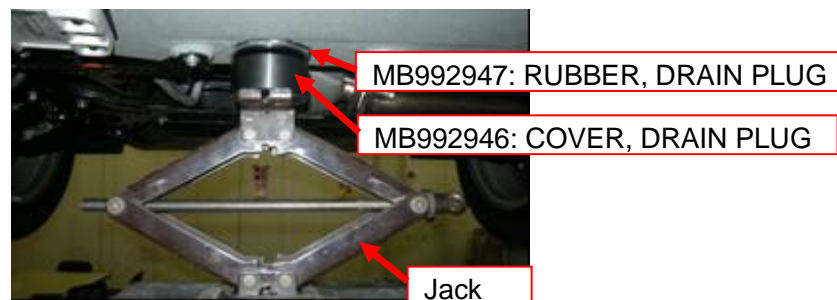

- ⑧ Fill water not containing salt, such as tap water, well water or pond water through the plug opening on the service lid into the drive battery until the water overflows.
- ⑨ Keep the drive battery filled with water for at least 84 hours (3.5 days). Electrolysis of water produces hydrogen inside the battery for that period. Keep the vehicle in an outside well-ventilated area with all windows, doors and tailgate open.
- ⑩ Remove the special tools from the bottom of the drain plug, and then wait until the water is drained completely.

Place a suitable tray under the drain plug to collect the drained water.

⚠ WARNING;

Do not drill an additional hole to fill water into the drive battery.
Serious injuries such as electric shock may be caused.

3) How to drain the filled water

Use a 12-mm wrench to remove the service hole lids on the bottom of the drive battery and drain the drive battery.

⚠ CAUTION;

- To drain the drive battery, always observe the specified procedure (removal of the service hole lids).
- The water drained from the drive battery shall be properly disposed of as an industrial waste according to local regulations.

Location of service hole lids for the drive battery.

The battery for a drive has two kinds of specifications.

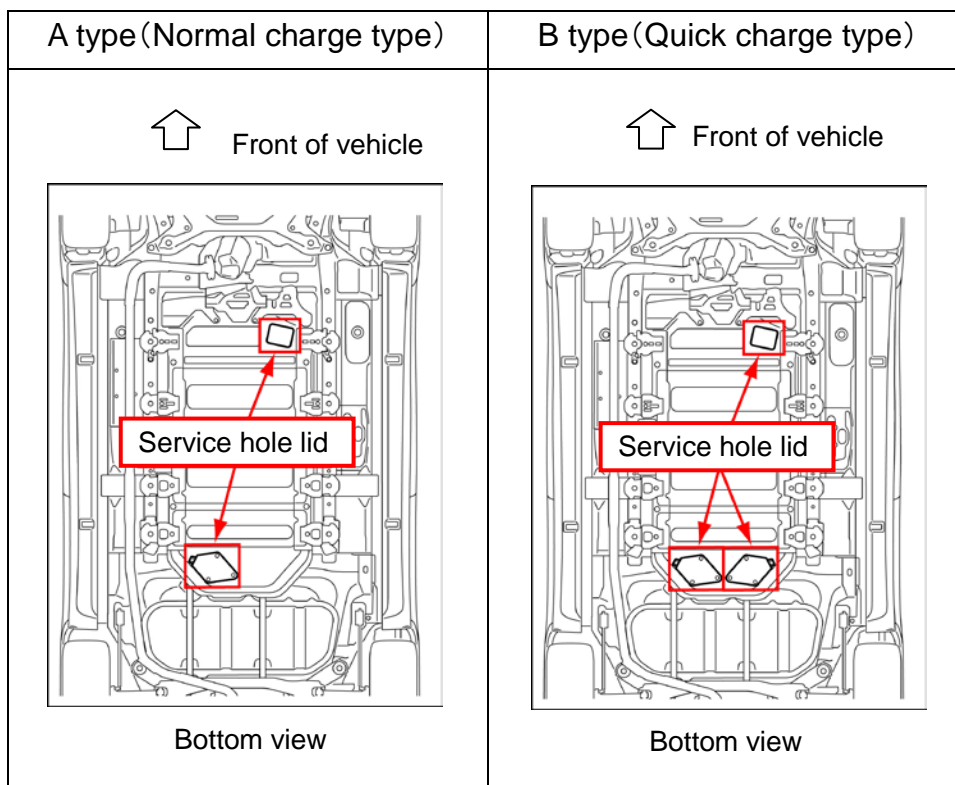

Removal of the service hole lid

- ① Removal of the earth bracket
- ② Removal of the service hole lid

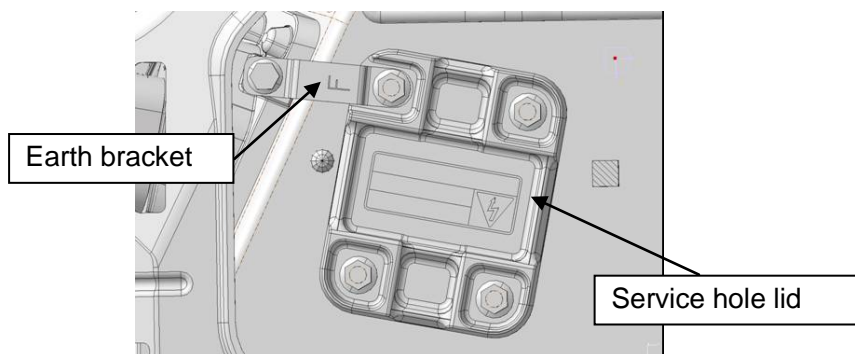

⚠ CAUTION;

The water drained from the drive battery shall be properly disposed of as an industrial waste according to local regulations.

(6) Case-B5:
Before righting a rolled over vehicle

Inspect the area for debris or objects that could damage the drive battery when the vehicle is righted. Right the vehicle slowly, taking care not to contact or damage the battery. If fuel leaks, observe the same procedure as for the conventional petrol models.

⚠ WARNING;

If the drive battery is damaged by objects (such as stone), the electrolyte may leak, causing electric shock.

Coloured portion: drive battery

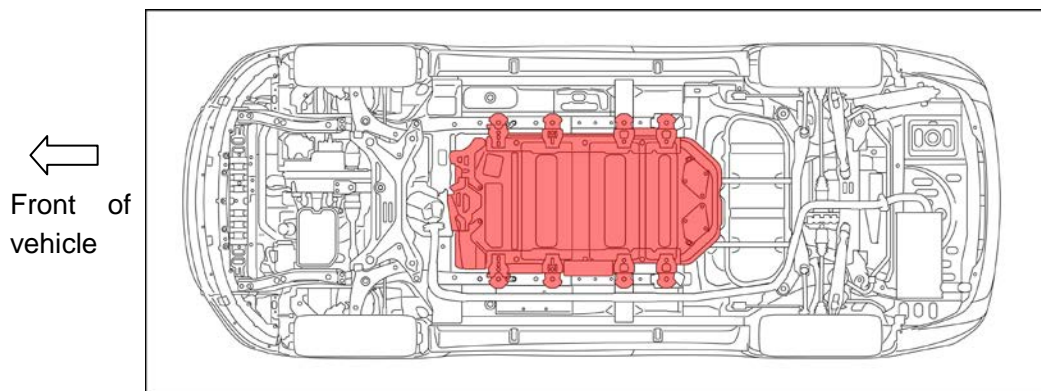

Bottom view

7. Vehicle specifications and precautions on how to transport the damaged vehicle

(1) Vehicle specifications

Total length	4,695 mm
Total width	1,800 mm
Total height	1,710 mm
Wheelbase	2,670 mm
Minimum ground height	190 mm
Vehicle weight	1,880 kg

(2) If the vehicle can be driven

You can drive the damaged vehicle for transportation purpose if all of the four conditions below are satisfied and there is no significant damage to the vehicle.

- A high voltage component and/or wiring cable is NOT damaged.
- Engine, electric motor (electric motor unit), transaxle (transmission), brakes, suspension, and/or tyres are NOT damaged.
- There are no fuel, oil and coolant leaks.
- Turn on the ready indicator by pressing the electric motor switch with the brake pedal depressed.

If the "READY" indicator lamp turns off and/or any warning lamps turn on, or if you detects an abnormal noise, smell and/or strong vibration from the vehicle during driving, the following procedure should be carried out:

⚠ WARNING;
Always wear appropriate insulating Personal Protective Equipment (PPE) to pull out the service plug.

- 1) Stop the vehicle as soon as possible in a safe location.
- 2) Move the selector lever to the P position and apply the parking brake.
- 3) Turn off the electric motor switch.
- 4) Wait for at least one minute, and then disconnect the 12V auxiliary battery negative terminal.
- 5) Wear Personal Protective Equipment (PPE) and remove the service plug.

(3) Transportation of the accident vehicle by tow truck

If the vehicle body or the suspension is damaged due to an accident, transport the vehicle on a flatbed truck or tow the vehicle with all wheels off the ground.

⚠ WARNING;

- Take care not to touch any exposed orange-coloured high voltage wiring cables (cutoff or break a plastic jacket), or high voltage components that might be damaged. If you touch them inadvertently, serious injury such as electric shock may be caused.
- If you may or have to touch any exposed orange-coloured high voltage wiring cables (cutoff or break a plastic jacket), or high voltage components, always wear appropriate insulating Personal Protective Equipment (PPE).
- When transporting the damaged vehicle, follow 5. (3) Case-A2 (removal of service plug). Then transport it using a flatbed truck.

⚠ CAUTION;

- If the 12V auxiliary battery charging level is too low or the auxiliary battery negative terminal is disconnected, you cannot move the selector lever from the P range.

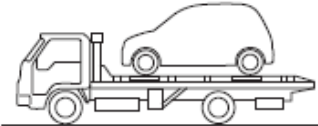
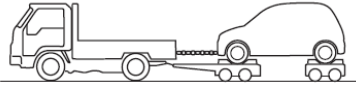
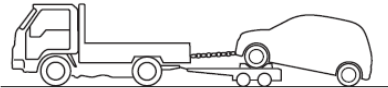
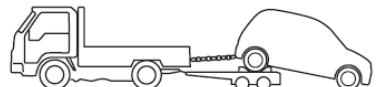
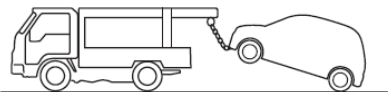
	How to transport the vehicle	Precautions and conditions
OK	Lift off the four wheels. 	- Move the selector lever to the P position and apply the parking brake.
	Lift off the four wheels. 	- If the suspension or the drive train is damaged, place the front or rear wheel on a cart. Do not tow the vehicle. - Move the selector lever to the P position and apply the parking brake.
Not OK	Lift up either front or rear wheel.  	- Do not transport the vehicle with any wheel on the ground. Towing the vehicle with the wheels on the ground may cause vehicle fire due to short circuit by the electricity generated from the electric motor (electric motor unit).
	Hang up the front wheel 	- Do not use a truck with sling-type towing devices. A bumper and/or a vehicle body may become damaged.

- The illustration shows examples only.

- When loading the vehicle on the truck, handle carefully to prevent further damage.

(4) Towing by tow rope

If there is no other alternative (e.g, moving the vehicle to a flatbed truck due to lack of fuel), and you must tow the vehicle using a tow rope, the vehicle speed must not exceed 30 km/h and the towing distance must be minimized. While towing, set the selector lever to “N (Neutral)” position.

⚠ WARNING;

• Towing the vehicle with the wheels on the ground may cause vehicle fire due to short circuit by the electricity generated from the electric motor (electric motor unit).
On vehicles with the Forward Collision Mitigation System (FCM) or the Adaptive Cruise Control System (ACC), these systems may be activated during towing. If the hybrid system is activated during towing, always turn off the FCM and/or the ACC.

• How to turn off the forward collision mitigation brake (FCM)

Description: When the power supply mode of the electric motor switch is turned on, the FCM should be activated.

The FCM OFF indicator in the multi-information display allows the driver to know whether the FCM is activated or deactivated. If the FCM OFF indicator illuminates, the FCM is deactivated.

Procedure: Press and hold the FCM OFF switch until the buzzer sounds with the FCM activated.

Caution: When you turn on the power supply mode of the electric motor switch at the next time, the FCM will be activated again. Therefore, when you tow the vehicle, deactivate the FCM again.

Note that the Ultrasonic misacceleration Mitigation System (UMS) will be also deactivated when you turn off the FCM.

<LHD>

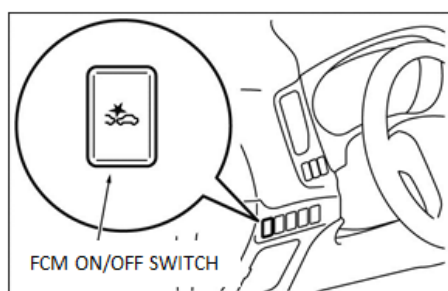

<RHD>

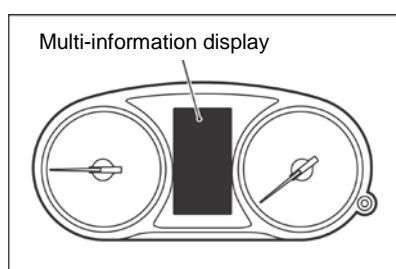
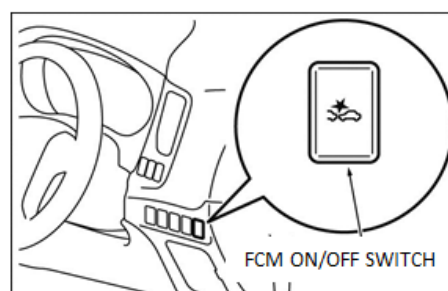

FCM OFF indicator



•How to deactivate the Adaptive Cruise Control System (ACC)

Description: When the power supply mode of the electric motor switch is turned on, the ACC will NOT be activated (default setting).

The ACC indicator in the multi-information display allows the driver to know whether the ACC is activated or deactivated.

If the ACC indicator illuminates, the ACC is activated.

Procedure: Press the ACC ON/OFF switch to deactivate the ACC.

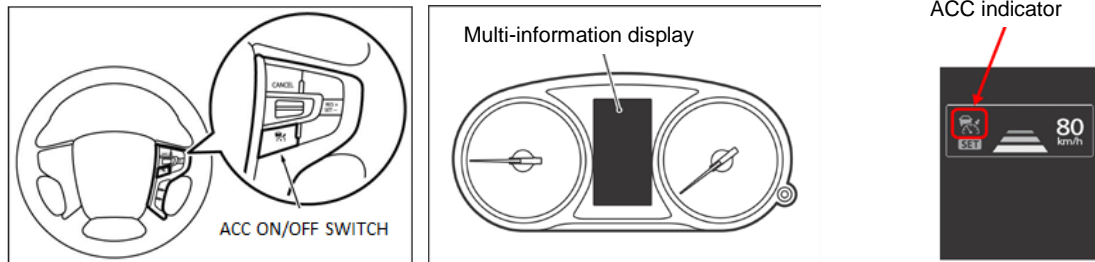

⚠ CAUTION;

- When towing the vehicle, handle carefully to prevent further damage.
- If you detects an abnormal noise, smell and/or strong vibration from the vehicle during towing, stop towing immediately.

① Hook a tow rope to the tow hook of the vehicle body.

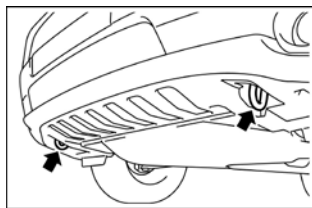

- The illustration shows examples only.

② When transporting the vehicle, keep the hybrid system activated.

When the hybrid system is deactivated, turn on the electric motor switch.

⚠ CAUTION;

- When the hybrid system is deactivated, the brake efficiency is reduced. Steering effort will also increase excessively.
- When the vehicle is towed with the electric motor switch ON, the 12V auxiliary battery may become discharged. In that case, the brake efficiency will be reduced and steering effort will also increase excessively, causing an accident.
- You cannot move the selector lever from the P range while the electric motor switch is at the OFF or ACC position.
- If the 12V auxiliary battery charging level is too low or the auxiliary battery negative terminal is disconnected, you cannot move the selector lever from the P range.
- Ensure there is proper tension in the tow rope at all times during towing to avoid breakage of the tow rope or the towing hook and to avoid injury to bystanders or vehicle damage.

-
- ③ Move the selector lever to the N (neutral) position.
 - ④ Turn on the hazard warning lamps to alert other road users.
 - ⑤ The regulations concerning towing may differ from country to country. It is recommended that you obey the regulations of the area where you are towing the vehicle.



WARNING;

Be careful not to apply excessive tension to the towing hook or rope. Otherwise, they may be broken. Metal debris may fly, resulting in injury to rescuer and/or vehicle occupants.

**DO NOT TOUCH!
DANGER!
IN PROGRESS!!
HIGH VOLTAGE WORK**

**HIGH VOLTAGE WORK
IN PROGRESS!!
DANGER!
DO NOT TOUCH!**

*Before any high voltage work commences, place this signboard on the roof of vehicle after folding on the dotted line.

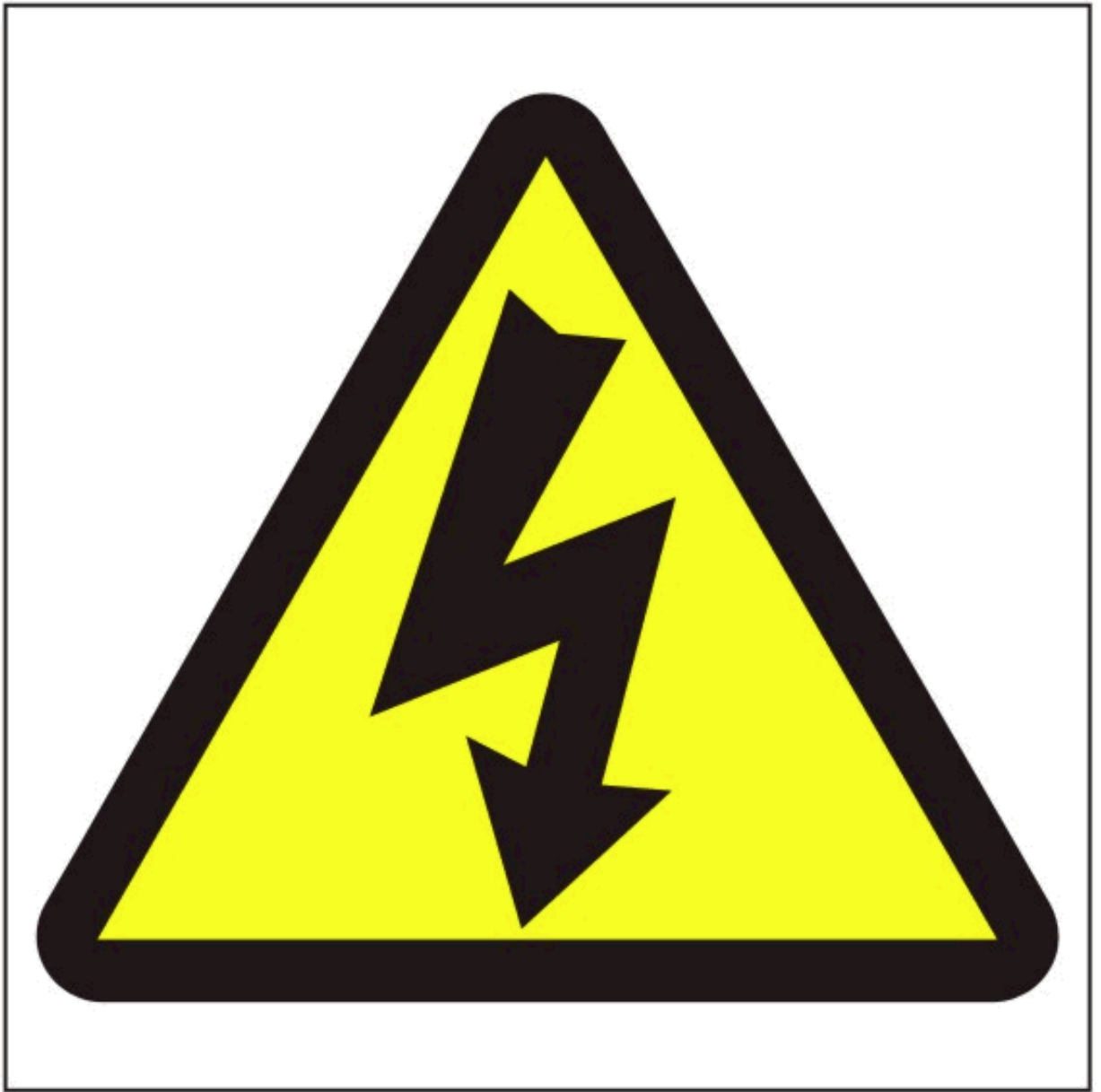

It is recommended that a warning sign (example provided above) is fixed to or on the vehicle during any emergency work on the vehicle. A sign that complies with local regulation should be used.